

ZAP

A PRODUCT OF TUCKER AUTO-MATION

8825-3-HPB

Heavy Duty Torsion Shaft
Mounted DC **Commercial**
Sectional Door Operator
that use **SafetySense™**



Tucker Auto-Mation has designed and developed a patented range of DC motor drives and controllers that operate without limit switches or a safety edge using a single phase supply. The operation of commercial sectional doors is now safer, smoother and exceptionally quiet using the compact and easy to install DC motors and controllers.



SAFER



EASY TO
INSTALL



QUIET

Tucker

AUTO-MATION

— DRIVEN —

a division of PORTALP USA, Inc

WWW.TUCKERAUTO-MATION.COM





Product Description

8825 - SERIES 3-HPB | Safety

- NEMA 4X compliance for the controller as a standard feature.
- Compact size reduces potential for lifting injuries during installation.
- Universal torsion shaft mounting system reduces the potential for unsafe work practices during installation.
- Fully adjustable automatic obstruction sensing system detects obstructions on any part of the door in the open or close direction while monitoring the entire door movement for unsafe operation or service conditions.
- Inherent soft start-soft stop, safety stop-reverse eliminates the mechanical stress damage to the door when the door reverses.
- Self determining limit system prevents thrown cables from debris, ice, and snow left in the door opening.

8825 - SERIES 3-HPB | Value

- Continuous duty rated low voltage motor.
- Ultra-Quiet DC Motor, will not thermally overload.
- Built in Service Due reminder may be activated to ensure regular maintenance based on cycles of usage.
- Fully programmable Timer-to-close.
- Built in interlock terminals to prevent door operation.
- Programmable mid-stop.
- Motor maximum amperage draw 5.8 Amps reducing number circuits required for multiple door applications.
- Automatic obstruction sensing system surpasses the capabilities of a sensing edge detecting obstructions on any part of the door, eliminating the cost of a safety edge and associated wiring which reduces the occurrence of catastrophic damage to the door.

8825 - SERIES 3-HPB | Simplicity & Reliability

- Simple one person installation that eliminate steel build ups, back hangs, welding, and specialty anchors.
- Simplistic maintenance design concept.
- PCB based system controller eliminates the cost of servicing electrical contactors, limit systems, and countless other parts. It is recommended to use a physical stop such as leaf or bumper springs at the upper limit.
- When the operator emergency release lever is disengaged the door operates by hand.
- Operates all lifts of sectional doors with counter-weights or torsion springs, including rear mount torsion.
- Versatile sectional door application mounting. May be mounted vertically, horizontally, upside down, inside the cable drum, remount torsion, all without requiring wall or ceiling mount.
- Simple wiring configurations and accessory modules that eliminate external limit relays to achieve various interlock configurations.
- Industrial components ensure years of service.
- Long life worm drive gear system.
- DC Motor and controller eliminates the problem of stuck motor switches, limit system failures, burned out starting capacitors and A/C motor malfunctions.

8825 - SERIES 3-HPB | Standard Features

- **SafetySense™** Door safety monitoring system
It turns every edge of the door into a contact safety edge and also monitors the entire door system for unsafe operational and service conditions.
- **Motor and controller**
Continuous duty rated DC Motor with controller, producing a powerful soft start/soft stop output of 1300 Newtons of force to drive commercial sectional doors while reducing mechanical impacts that cause premature wear of door components.
- **NEMA 4X rated controller case**
ZAP Controllers and push buttons are NEMA 4X compliant as a standard.

Drive reduction

Worm drive gearbox & V-belt reduction drive with floor level, adjustable belt tensioning /emergency release lever.

Wiring type

C2 (factory default), B2 failsafe is standard with the addition of approved photo eye.

Radio control and external receiver terminals

Terminal strip provided inside the controller to provide quick, convenient connections for adding external radio control receivers from any desired manufacturer.

Bearings and belts

Drive systems use industrial ball grade bearings and automotive grade long life v-belts. Our simplistic service design concept allows simple service of components in a matter of moments.

Construction

Heavy-duty 8-gauge electro-plate finish steel frame, industrial bearings, worm drive gears, aluminum drive pulley, secured with key stock and set screw for simple servicing.

Push button station

Control unit acts as the standard 3-button station for open/close/stop functions. Controller may be mounted remotely up to 24 feet away from the operator, provided it is to be wired with other external control devices that are designed to function as the primary door controls. Power supply is wired directly to the controller not the motor. Low voltage motor cable is supplied for easy wiring of the motor.

Automatic obstruction sensing system

Inherent motor current sensing system monitors the entire door system for obstructions and unsafe operating conditions in both directions of travel. The system provides protections unavailable with traditional commercial operators and can automatically sense obstructions like locks, broken springs, unsafe service conditions, and other obstructions that cannot be detected by reversing edges and photo cells.

Safety stop and reverse

Inherent motor current sensing system automatically incorporates safety stop before reopening in soft start.

Auto-close timer

Fully programmable auto-close timer automatically closes the door. (4 minutes) Requires the addition of approved photo cell.

Prevent door operation interlock

Built in interlock to prevent door operation, used with truck restraint systems, shared track applications or pass doors.

Emergency egress manual operation

Emergency manual operation using a ground level over-ride lever disconnect. When lever is released, the door will operate manually by hand as if no operator is connected to the door. This unique system eliminates the need to electrically interlock the disconnect as the operator has no mechanical limits and physically disconnects from all drive systems when released. It also provides ground level adjustment of the motor drive belt.

Max run time protection

Inherent motor current sensing system provides automatic max runtime protection.

Service due reminder

May be activated to ensure regularly scheduled maintenance based on cycles of usage.

Versatile mounting configurations

8825 may be mounted in standard vertical, horizontal, inverted, inverted center mount inside the cable drum, or rear mount torsion configurations. Some applications may require the use of a longer Bowden cable for proper installation.

8825 - SERIES 3 - HPB | Options & Accessories

■ Fraba Optoeye UL 325 Compliant Monitored Entrapment Protection Device

401002 photo eye is a Nema 4X UL 325 Compliant Monitored Entrapment Device designed for durability in all commercial applications.

■ Receivers and transmitters

Terminals are provided inside the controller to facilitate the use of a 24VDC external receiver from any radio control manufacturer.

■ Rear mount torsion kit

Bowden cable 17.75ft.

■ Adapter Insert

ZA0191 Adapter insert for converting operator to accept 1" live axle shafts.

■ Battery back up

8830 Battery Back up systems allows operation of the operator during power outages.

Auxiliary input expansion module

871 module allows for expansion of input functions beyond the available connections on the controls board. It provides additional open, stop, close and cyclic operation input connections as well as an additional 24VDC supply.

Fire station module

871 FS allows the incorporation of a second set of photo cells above man traffic height that will prevent the auto-close timer from timing out and closing a door before the vehicle has departed the facility. Once the vehicle has departed the opening fully, the timer is released.

Dock interlock/Traffic light control w/adv. warning

82DTLM and the 822 Modules provide a N/O relay that closes when the door operator is in the fully opened position. It may be used as a dock interlock or to interlock a door that shares the same track system. Provides terminals to operate red/green driver communication lighting where mechanical dock levelers are used. 822 module provides advance warning of pending door closure with activation of the delay close programming. Terminals provided on 82DTLM may also be used to operate security, heating or other 5V to 240V devices up to 5 amps. Expansion port included for the addition of 871 FS, or 871 inter face expansion modules.

Closed interlock/Traffic light control w/adv. warning

82TLM and the 821 Modules provide a N/O relay that closes when the door operator is in the fully closed position. It may be used as a sally port inter lock or to interlock any device that requires the door to be in the closed position. Provides terminals to operate red/green through traffic lights where it is desired to know the

8825 - SERIES 3 - HPB | Technical Information

Lift Requirement	Low Headroom	Standard Lift	High Lift to 54"	High Lift above 54"	Vertical Lift
Door Size W X H					
10'-24"W X 6'-12'H	8825-3-HPB	8825-3-HPB	8825-3-HPB	8825-3-HPB	8825-3-HPB
10'-20"W X 12'-15'H	8825-3-HPB	8825-3-HPB	8825-3-HPB	See 8825-3-HPC	See 8825-3-HPD
Please read the instructions fully or attend training online before installation. Consult factory for door sizes beyond scope provided above. The maximum door weight for sizes listed above is 1800 Lbs. The minimum door height 7'.					

ZAP 8825 - SERIES 3 - HPB

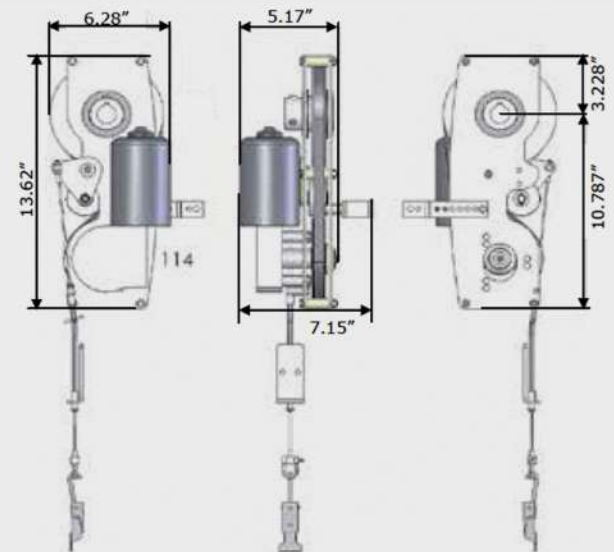

Controller case/push button:	NEMA 4X/IP66
Controller dimensions:	8.7" H X 10.6" W X 4.5" D
Single phase voltage:	115V US, 208-230V US, 208-230V EU
Amp draw:	5.8 A
Power rating:	2000 Newtons Equivalent to 1.5 HP
Control circuit voltage:	6VDC
Operator Motor Head Rating:	NEMA 4*
Motor Type:	DC Gear Reducer
Motor Voltage:	48-54 VDC
Limits determination:	Physical/Self Calibrating
Duty cycle rating:	Continuous
Operating temp range:	-22 deg F to 212 deg F
Overload protection:	Inherent motor current sensing
Torsion shaft type required:	Solid w/keyway or hollow tube
Torsion shaft length required:	4.5" beyond outer edge of track
Fits torsion shafts diameter:	1"
Side clearance required:	5" min for motor only
Replacement red motor P/N:	600814
Replacement belt:	8825-HPB AX29

* When installing this unit in a wet location a protective piece of shrink wrap must be applied over the motor plug connection to meet **NEMA 4**.



MANUFACTURED IN

USA

French Innovative Design

SAFETY MEETS SIMPLICITY



Tucker Auto-Mation - ZAP a division of **PORTALP USA, Inc**
11075 Parker drive Irwin, PA 15642

Toll Free: **1-855-8 TUCKER**
Tel: **412-506-3830**

Email: sales@tuckerzap.com
www.tuckerauto-mation.com